

**DACIA**

**JOGGER**

→ 02.2022

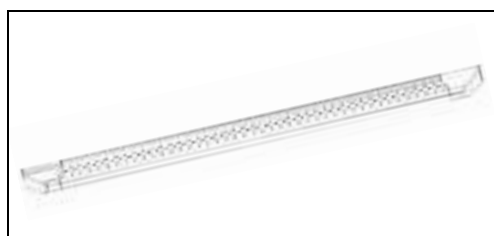

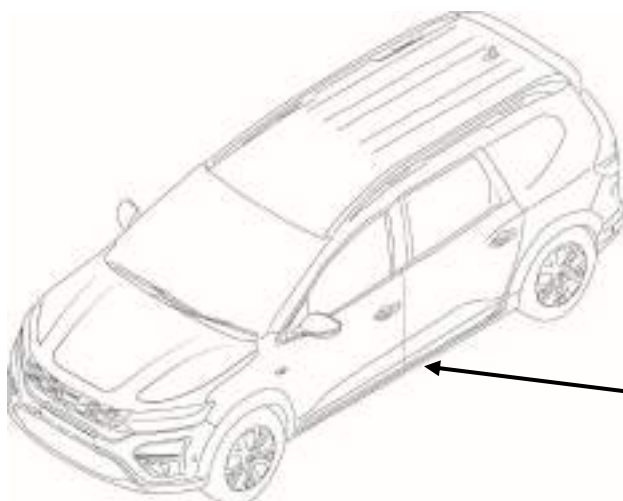

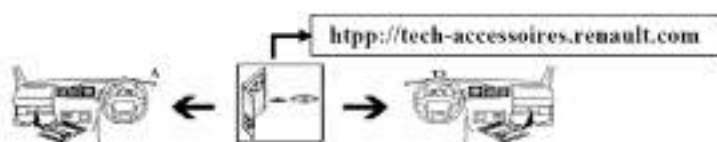





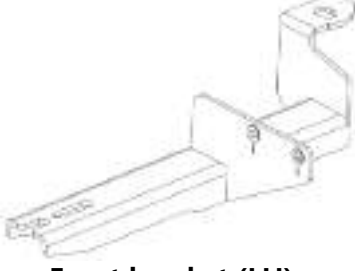
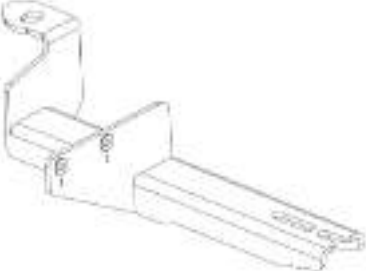

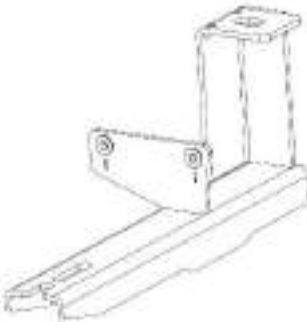
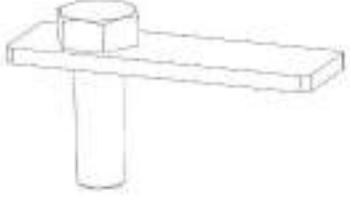
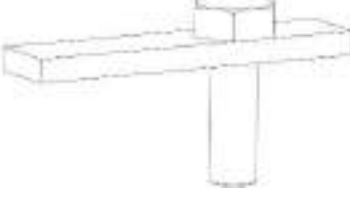



82 01 741 626  
76 84 786 91R





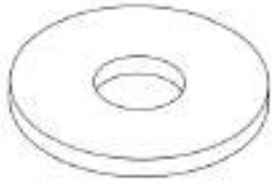

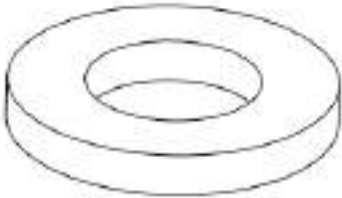
FRA Instructions de montage  
CES Pokyny pro montáž  
DNK Monteringsveiledning  
DEU Einbauanleitung  
ENG Installation instructions  
SPA Instrucciones de montaje  
EST Paigaldusjuhised  
FIN Asennusohje  
ELL Οδηγίες συναρμολόγησης  
HRV Návody k montáži  
HUN Beépítési utasítások  
ITA Istruzioni per il montaggio  
JPN 取付説明書

KOR 조립설명서  
LIT Montavimo instrukcija  
LAV Montāžas instrukcijas  
NLD Inbouwhandleiding  
NOR Monteringsveiledning  
POL Instrukcje wbudowania  
POR Instruções de montagem  
RON Instrucțiuni de montaj  
RUS Инструкция по монтажу  
SLK Návod na zabudovanie  
SLV Navodila za inštalacijo  
SWE Montageanvisning  
TUR Montaj talimatları

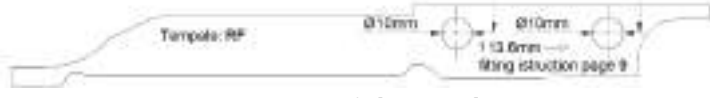
No.	QTY	Name			
1	2	 <p>Jogger side step</p>			
No.	QTY	Name	No.	QTY	Name
2	1	 <p>Front bracket (LH)</p>	3	1	 <p>Front bracket (RH)</p>
4	2	 <p>Mid bracket</p>	5	1	 <p>Rear bracket (LH)</p>
6	1	 <p>Rear bracket (RH)</p>	7	2	 <p>T bolt M12</p>
8	2	 <p>T bolt M8</p>	9	2	 <p>L bolt M8</p>
8201741626/--A		15/03/2022			2/24

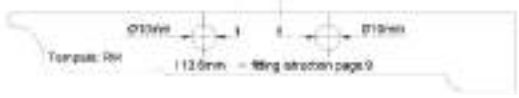
No.	QTY	Name	No.	QTY	Name
10	2	 Bushing	11	2	 Rubber
12	2	 PVC clamping piece φ12	13	2	 PVC clamping piece φ8
14	12	 Button head screw M6 X 16	15	12	 Spring washer D6
16	16	 Flange nut M8	17	16	 Enlarged flat washer D8
18	2	 Flange nut M12	19	16	 Enlarged flat washer D12
20	12	 Flat washer D6	21	1	 Fitting instruction
8201741626/--A		15/03/2022			3/24

No.	QTY	Name
22	1	 <p>Front left template</p>
23	1	 <p>Front right template</p>
24	1	 <p>Middle left template</p>
25	1	 <p>Middle right template</p>
26	1	 <p>Rear left template</p>
27	1	 <p>Rear right template</p>

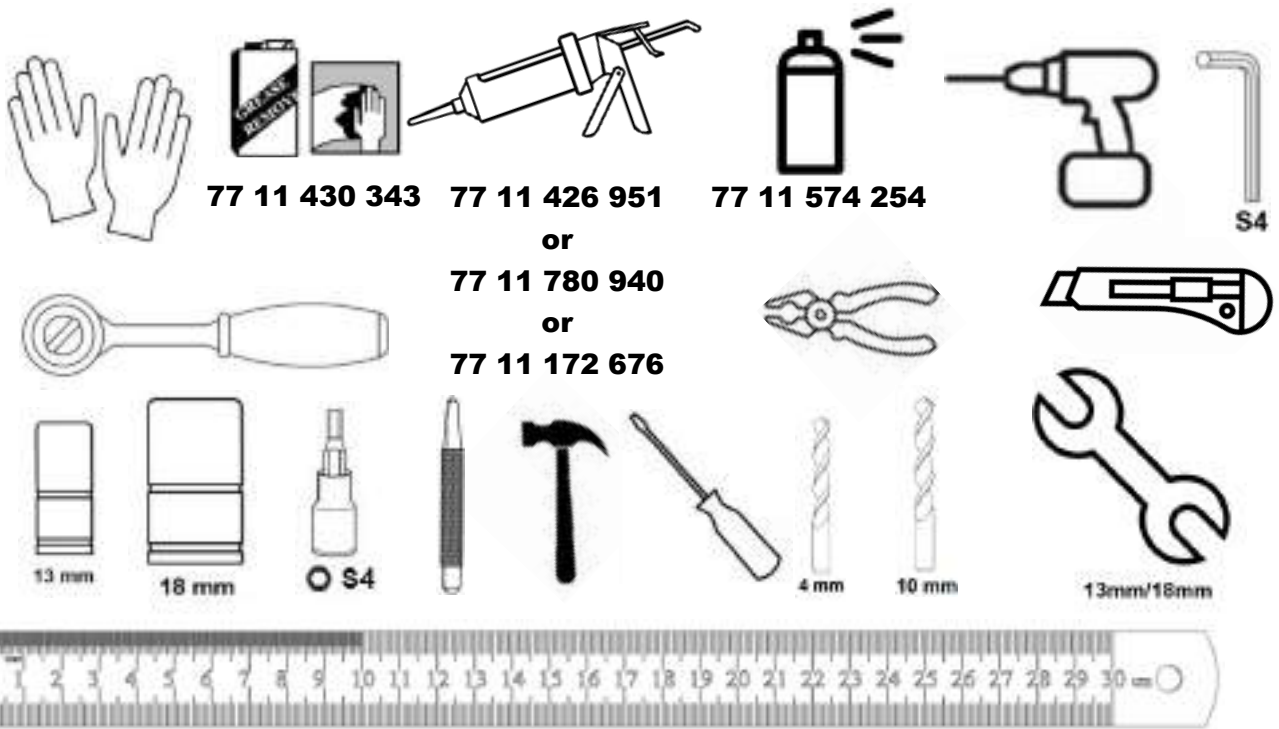

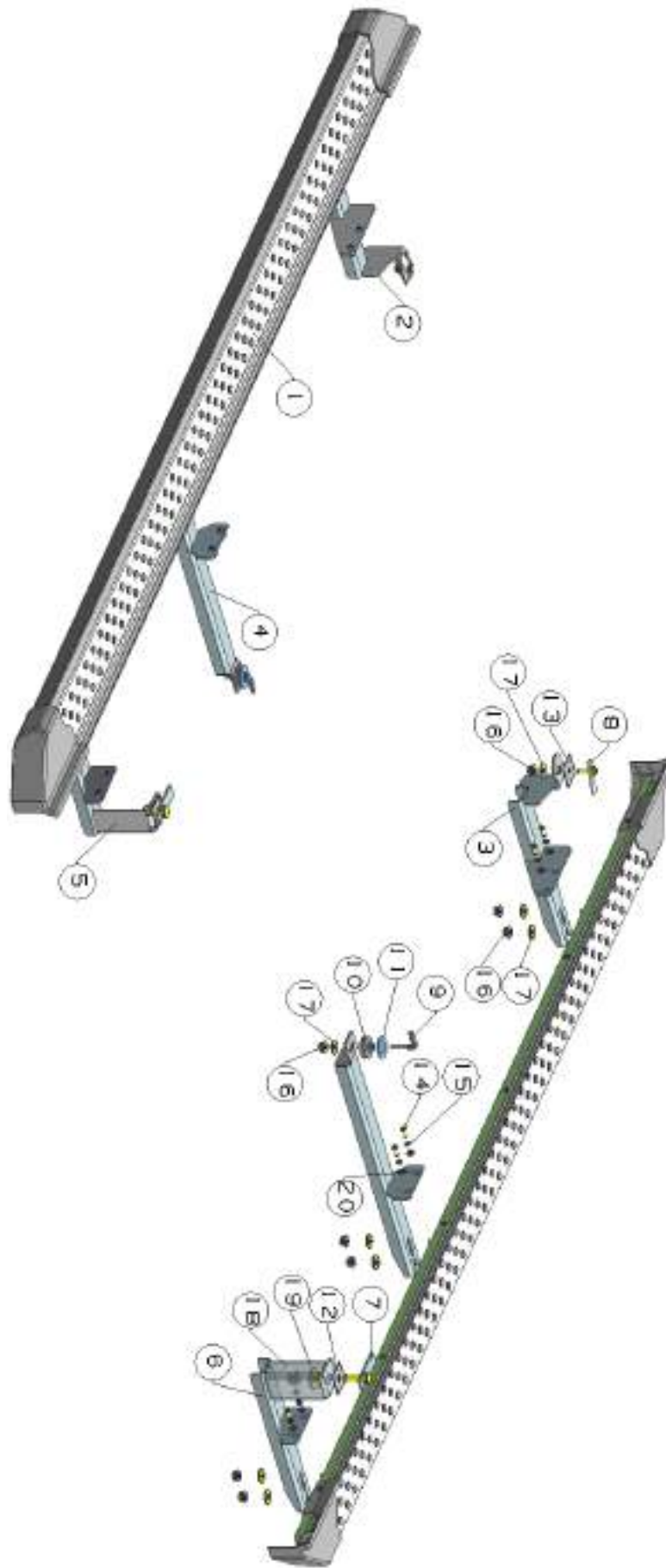

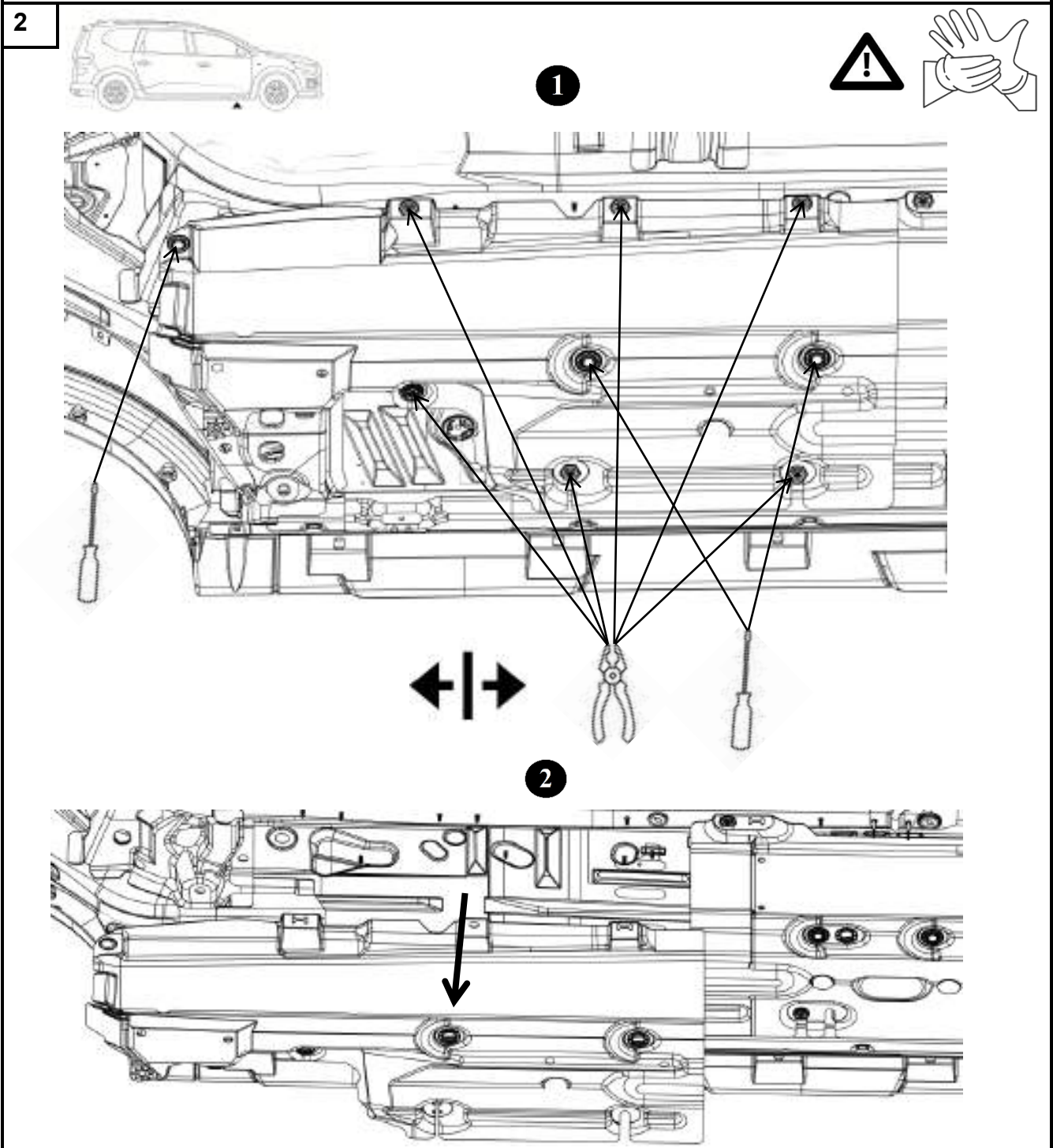
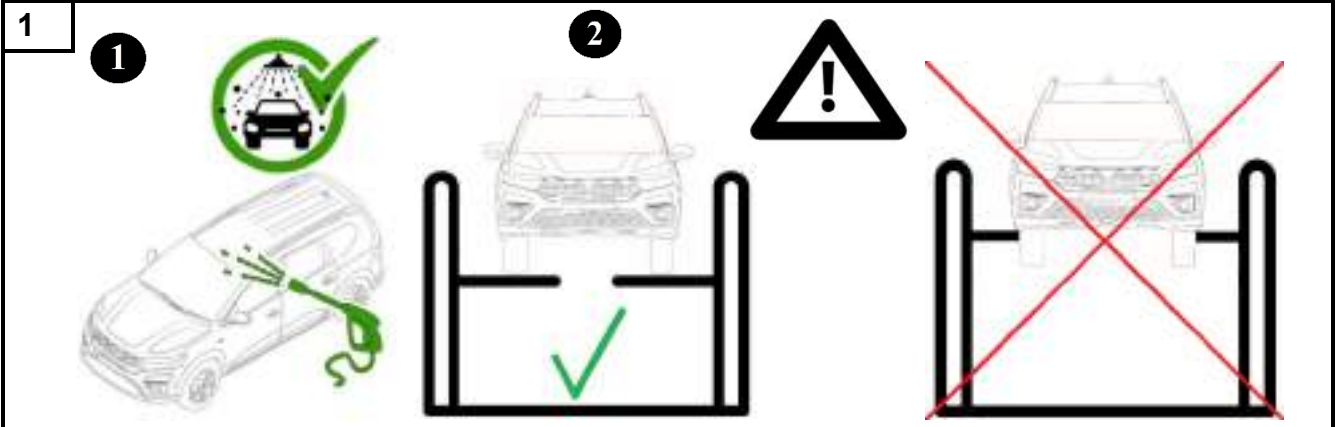

3



1

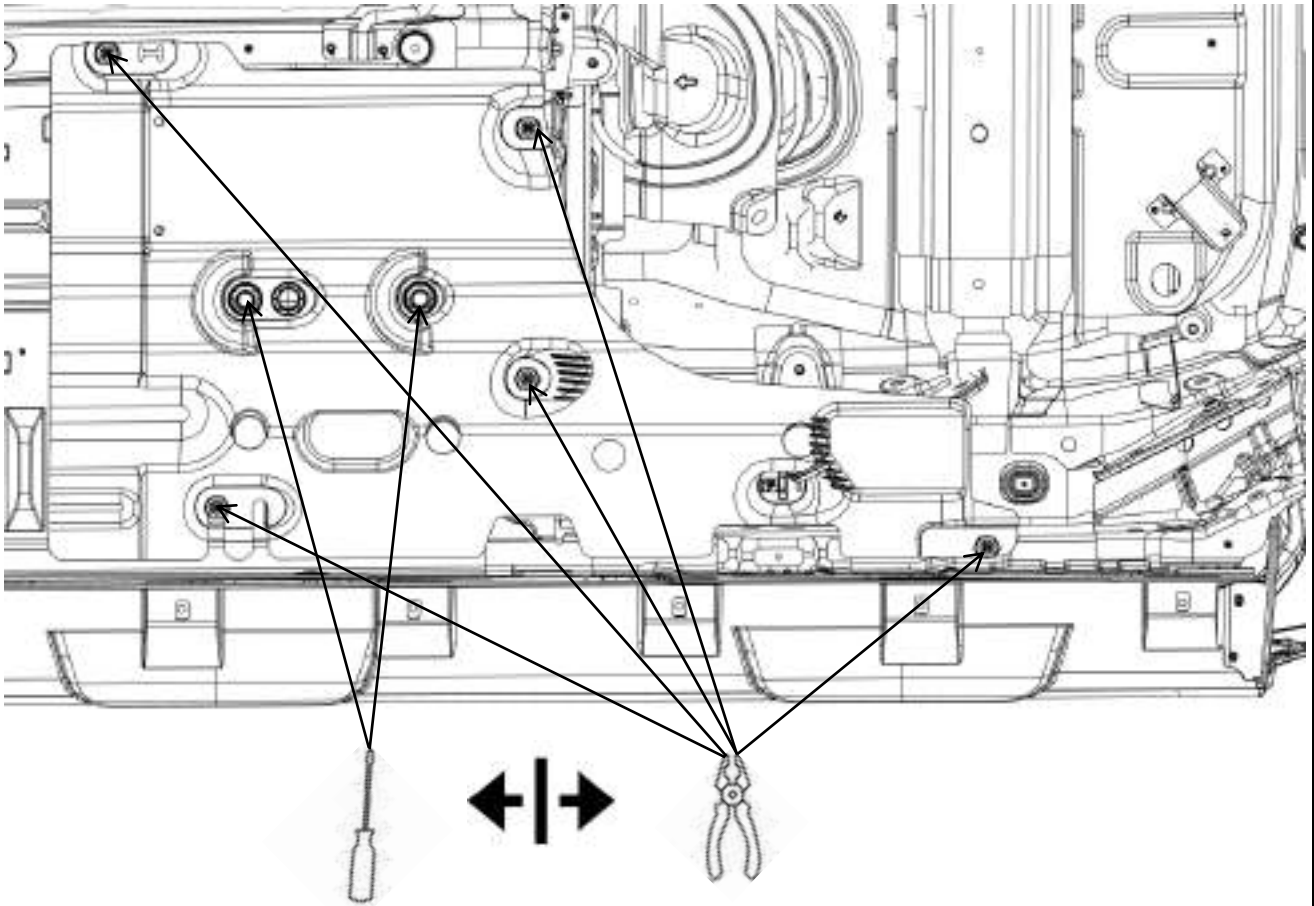

2

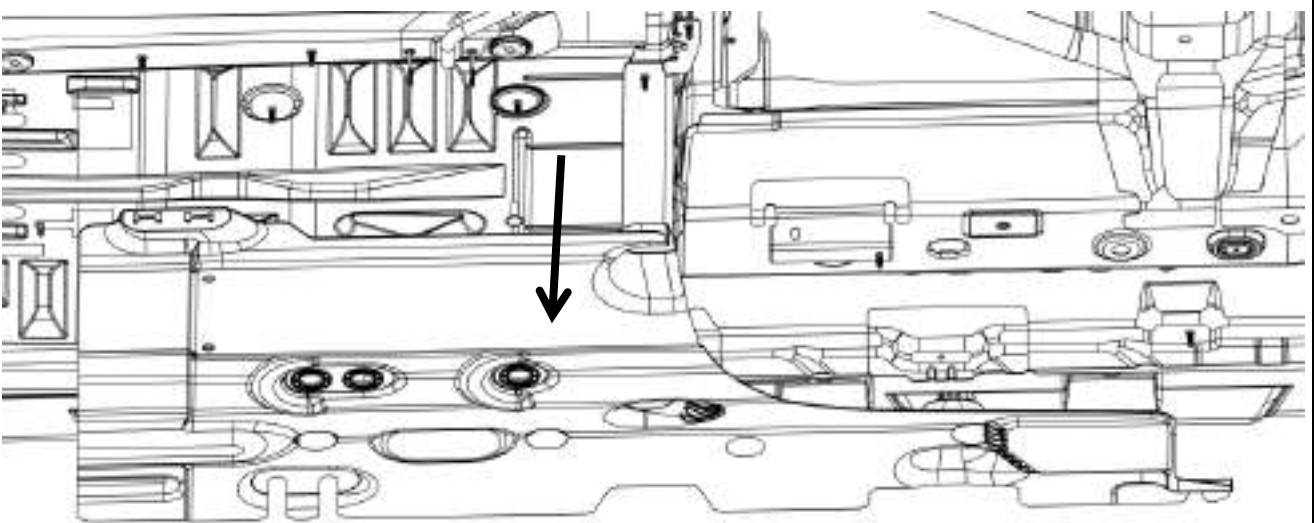

4

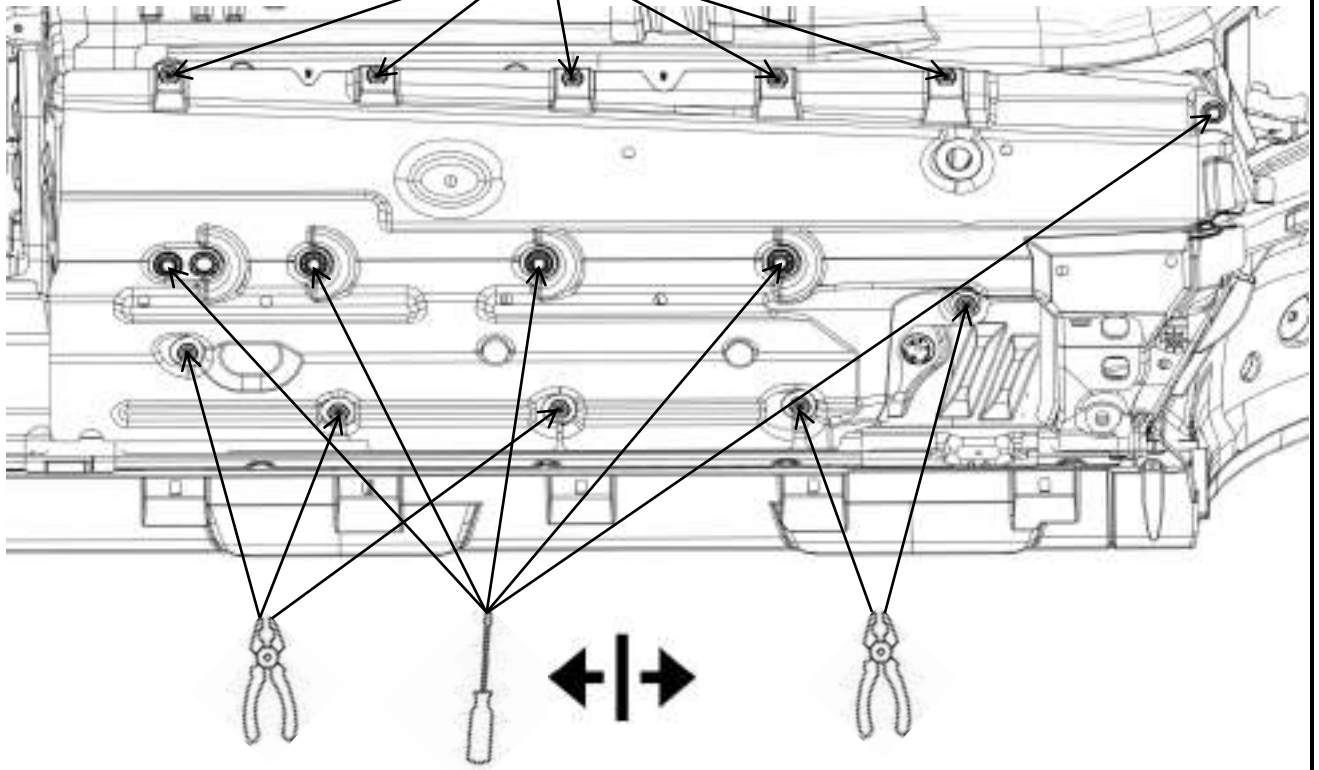
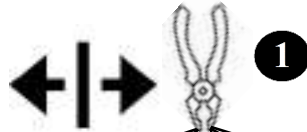

2

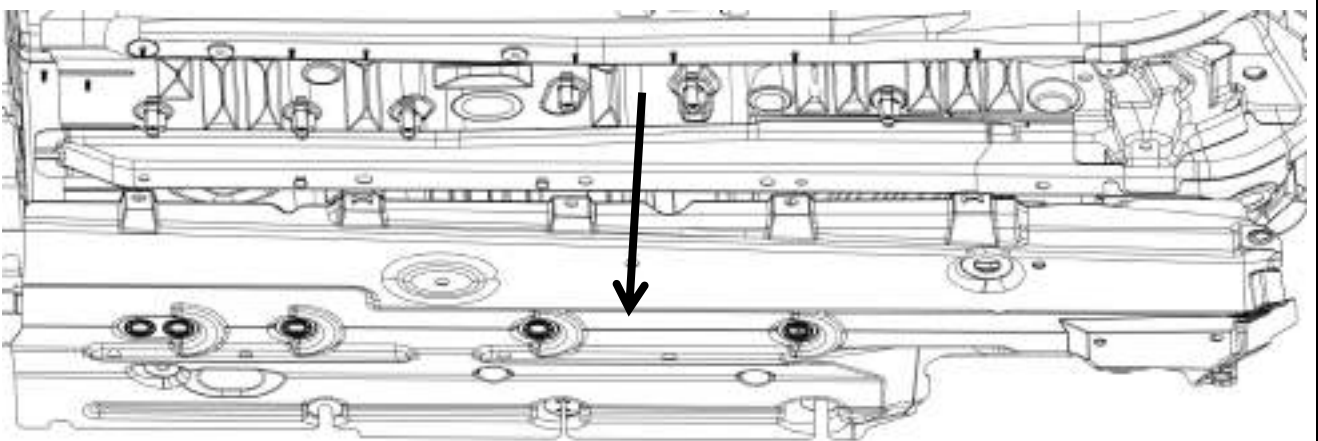



5

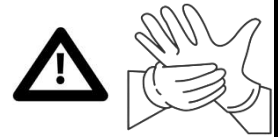

1

2

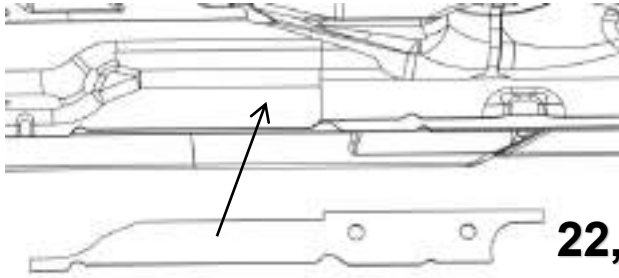

22,23

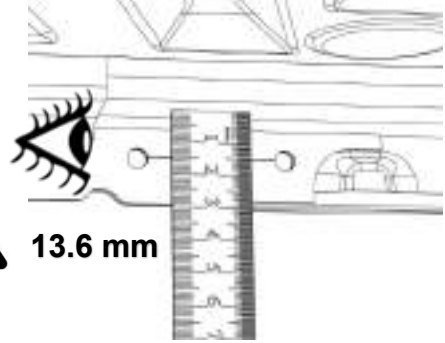

13.6 mm

3

5

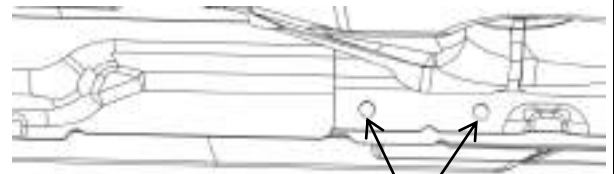
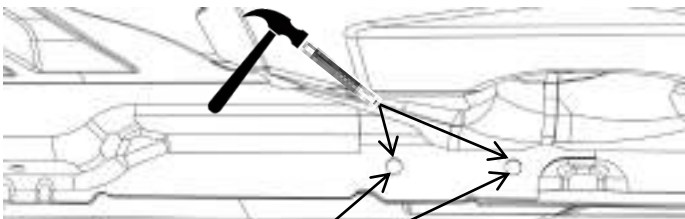

4

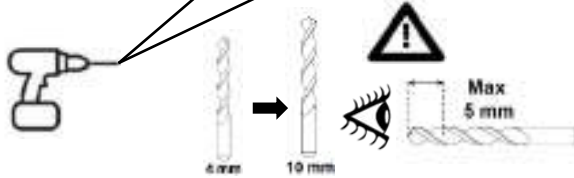

6 mm 10 mm

Max 5 mm

6

7

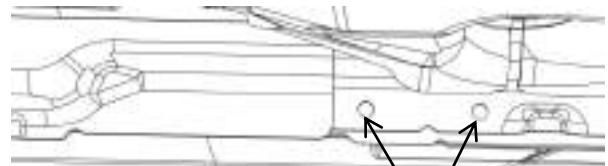
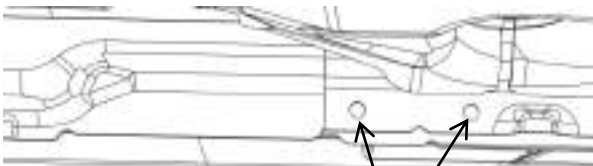

77 11 430 343



15 min



77 11 574 254

6

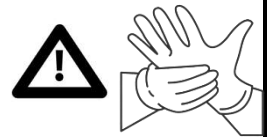

1

2

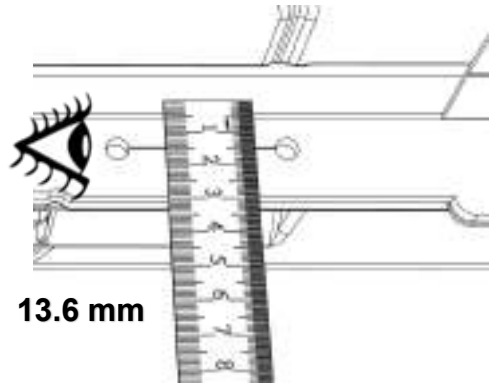
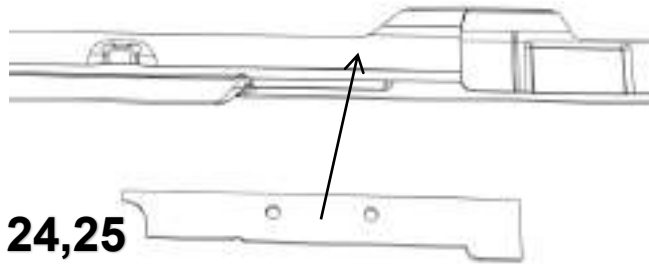

3

5

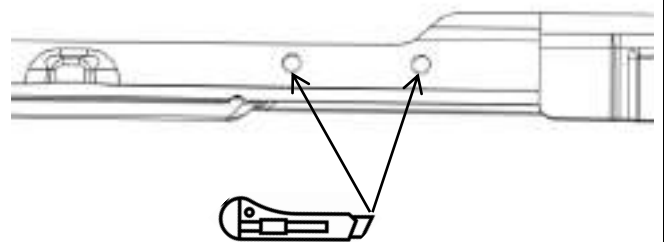
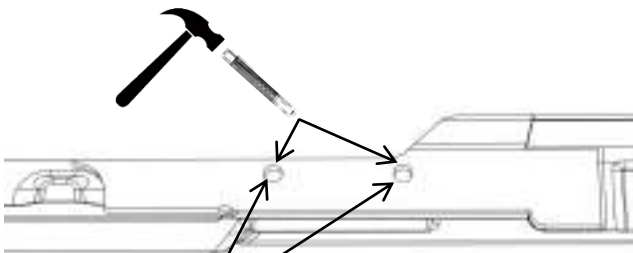

4

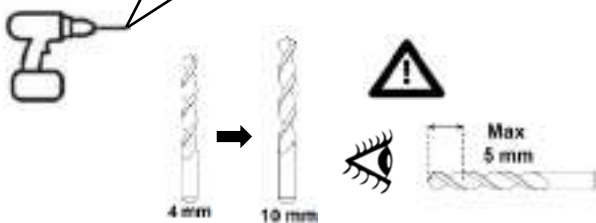

6

7

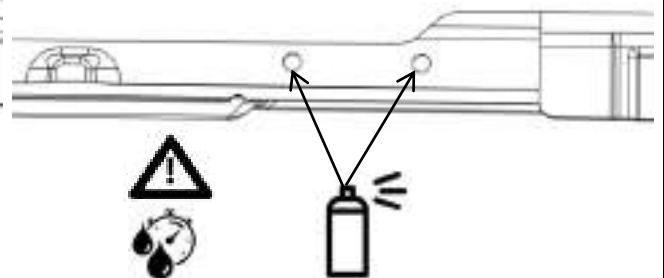
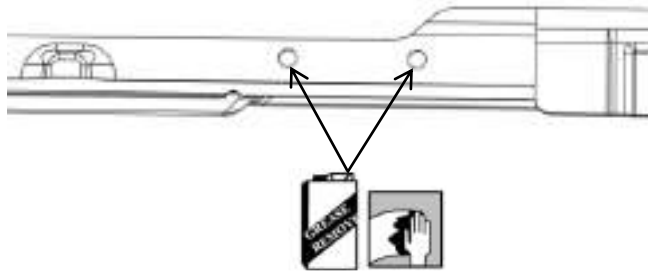

77 11 430 343

15 min 77 11 574 254

7



1

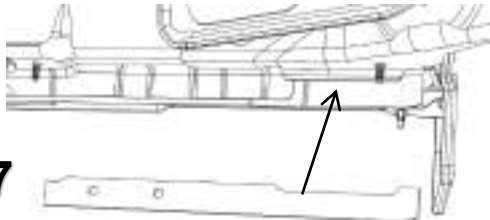

26,27

2

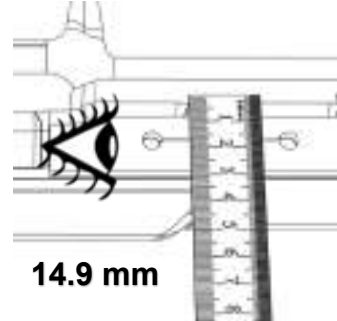

14.9 mm

3

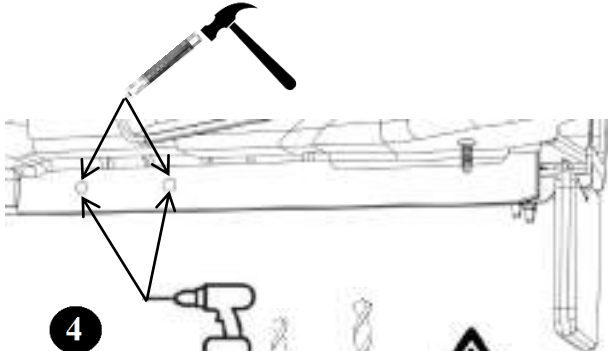

5

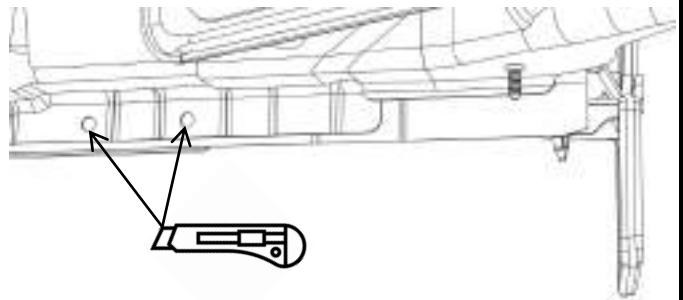

4

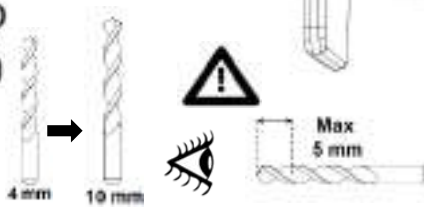

6

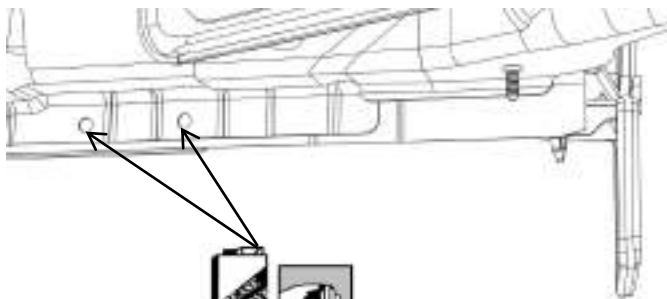

77 11 430 343

7

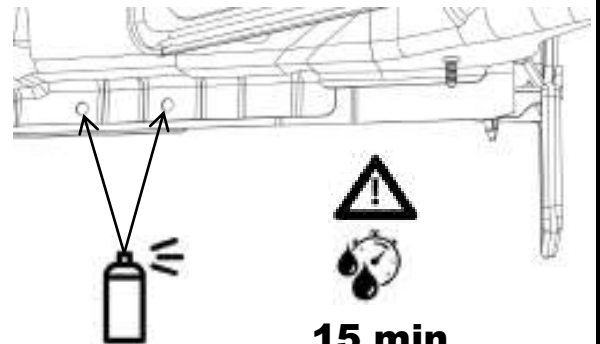

15 min

77 11 574 254



1

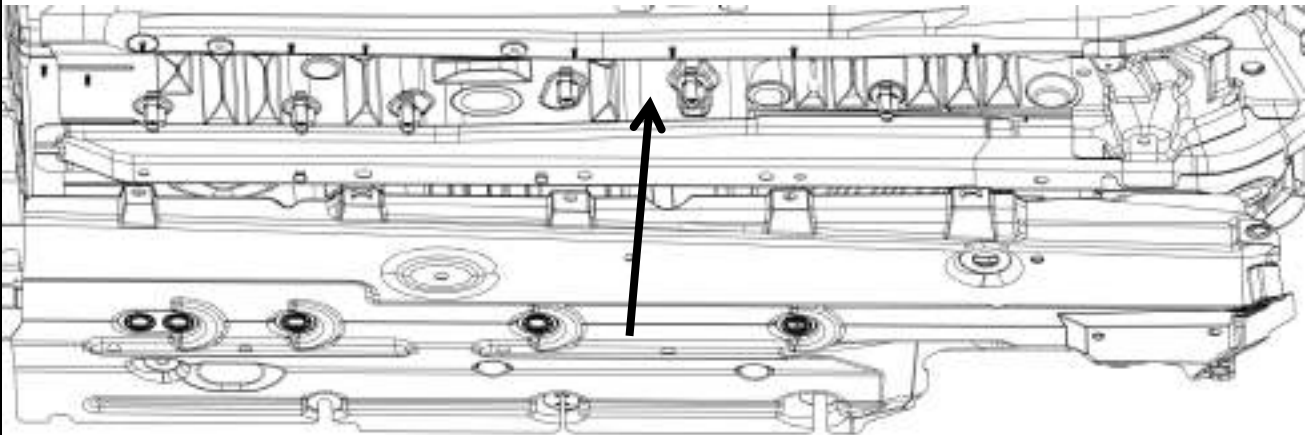

2

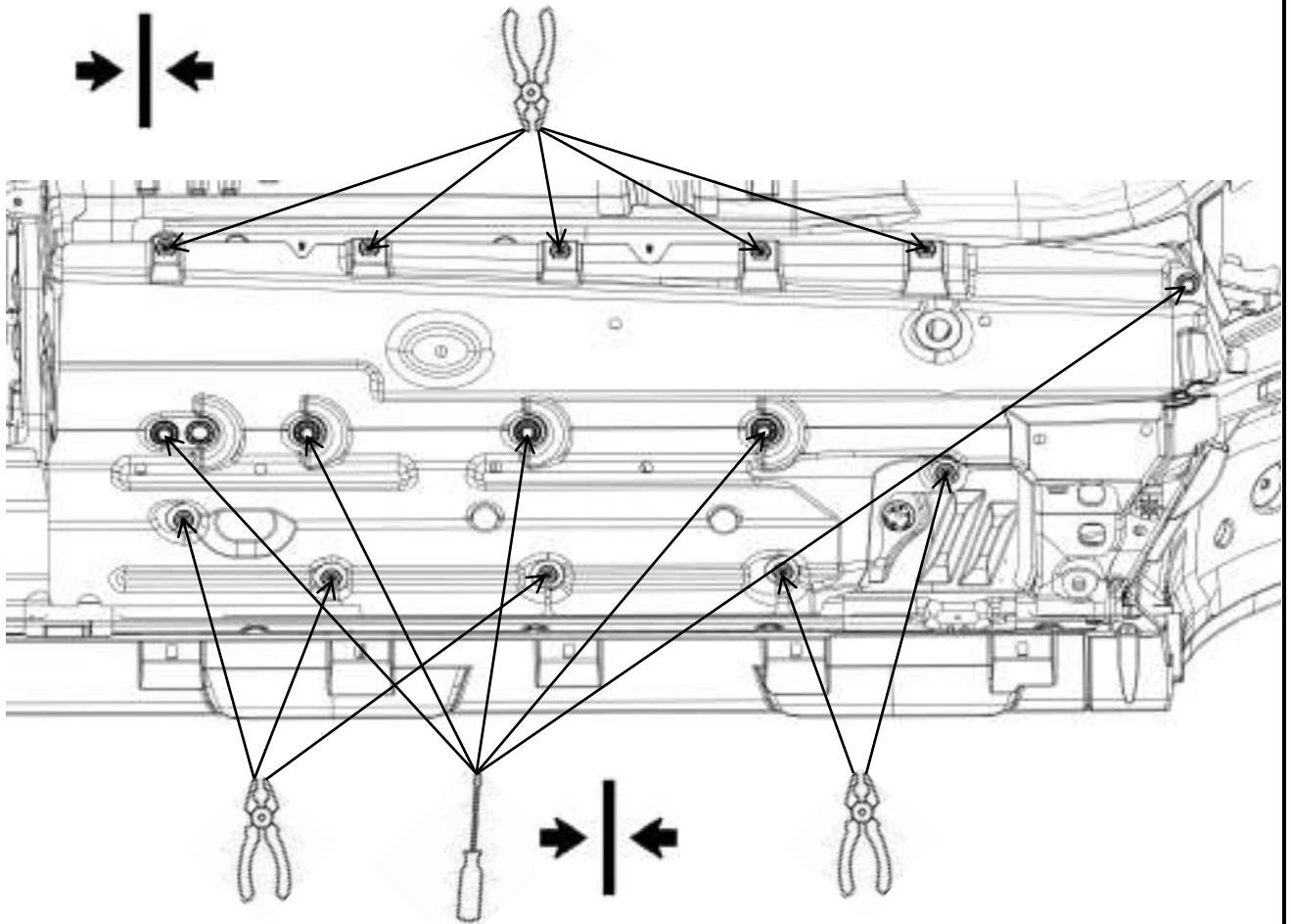
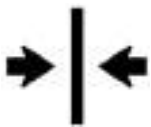

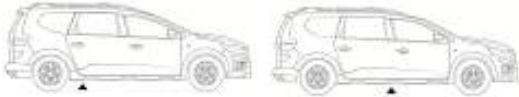

1

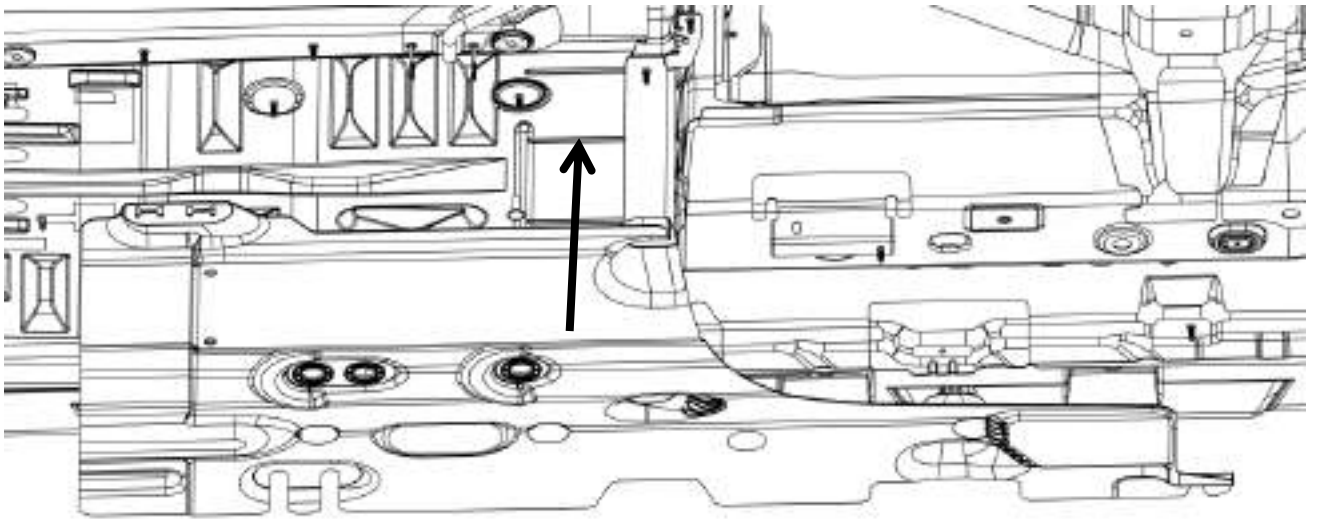

2

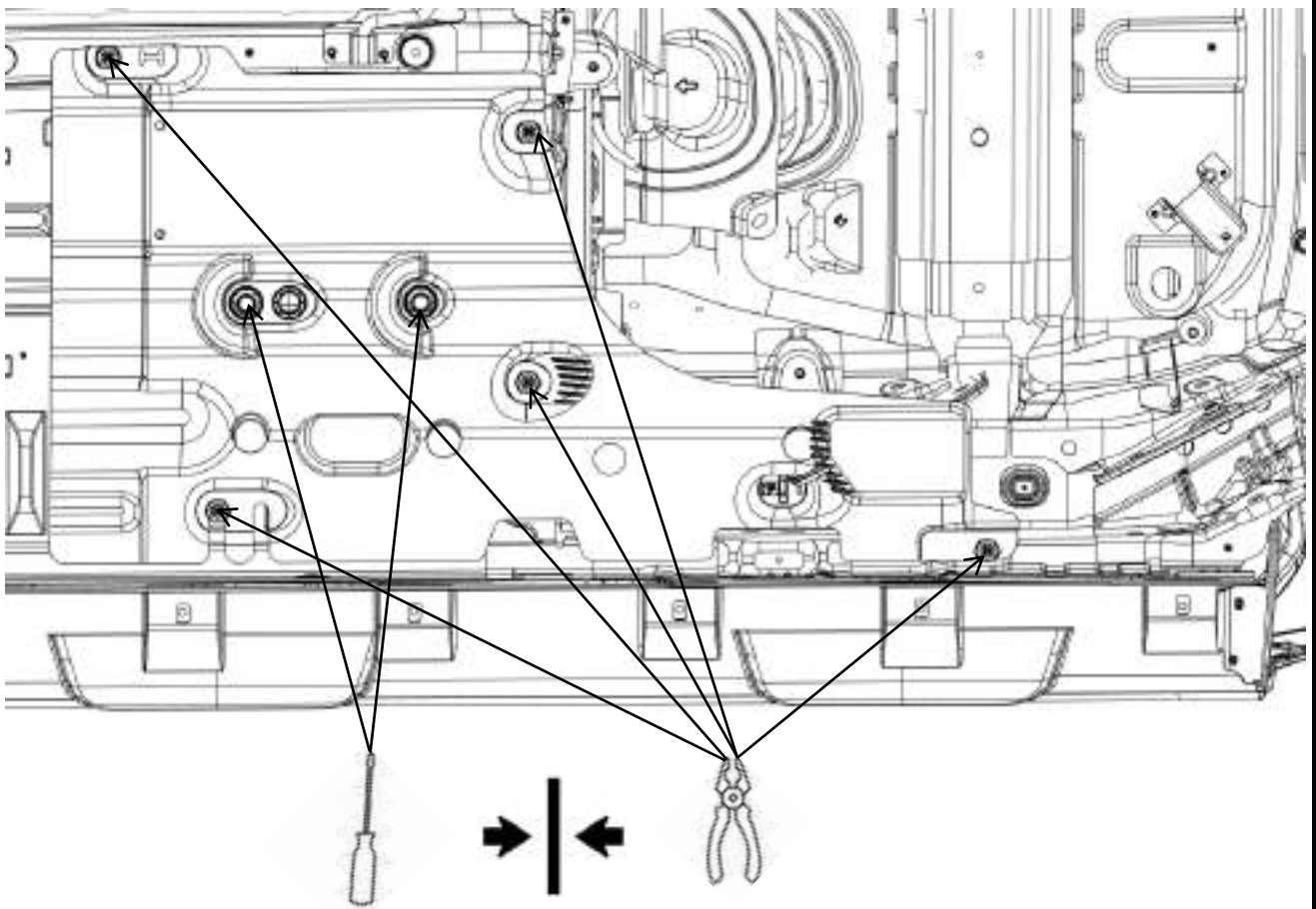



1

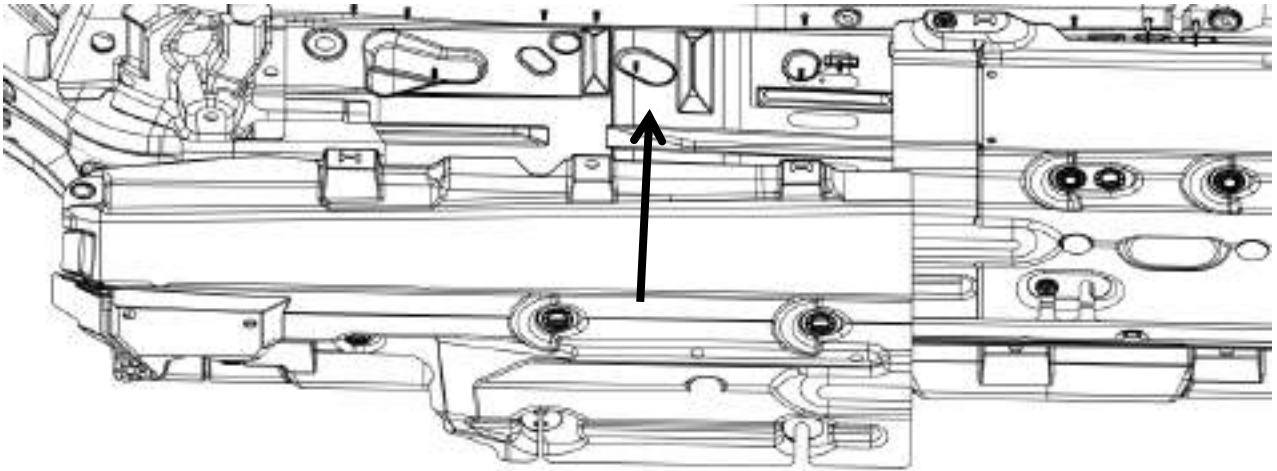

2

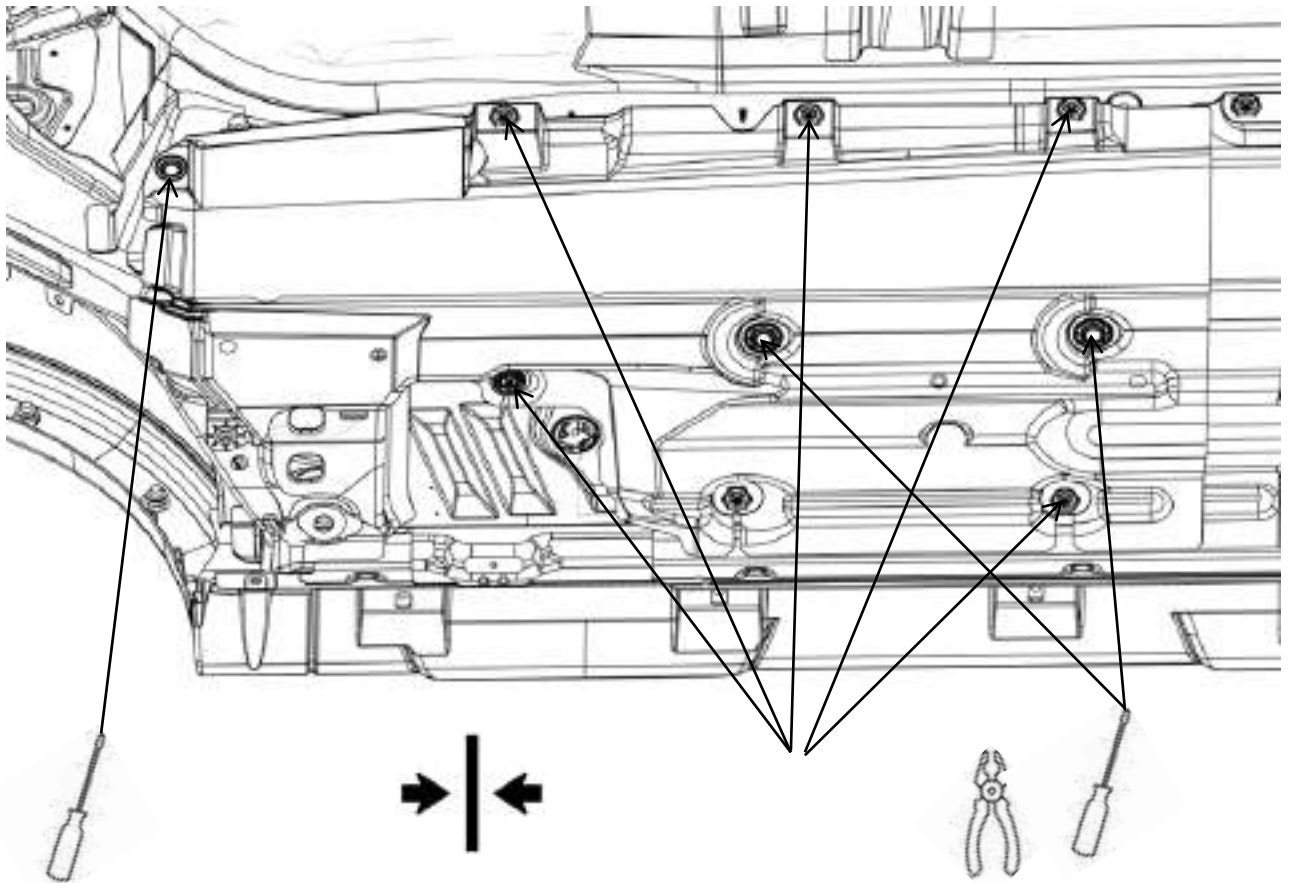

11



1

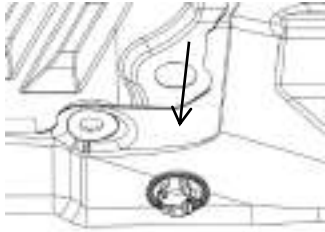

3



2

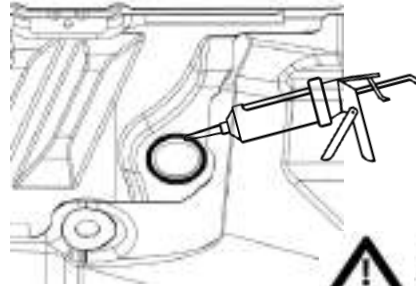

4

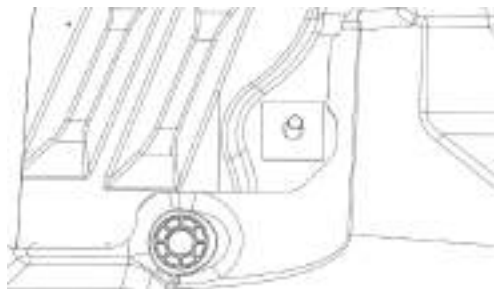

77 11 426 951

or

77 11 780 940

or

77 11 172 676



15 min

12



1

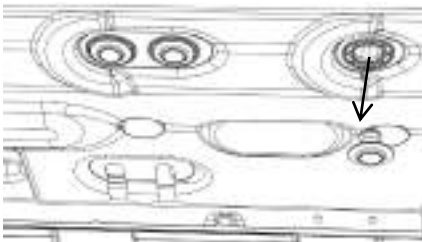

2

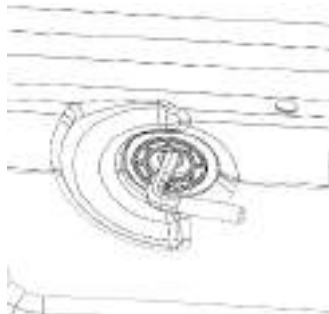

3

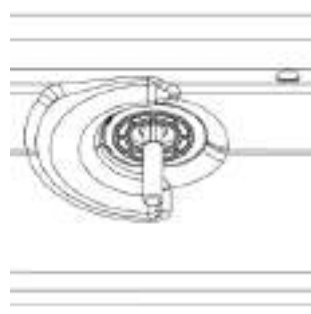

13



1

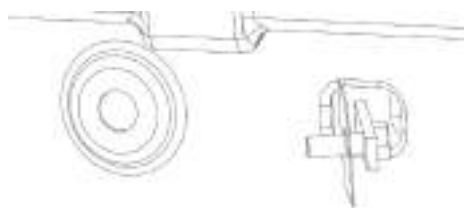

2





1

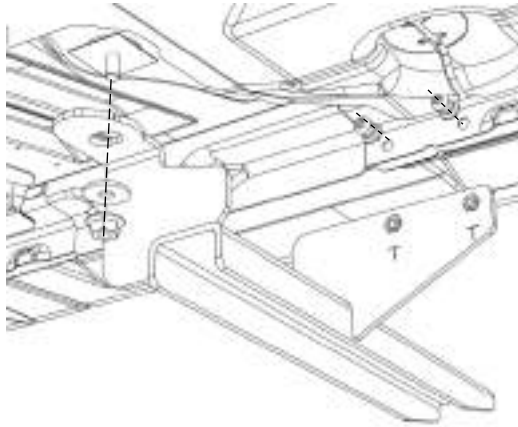

2

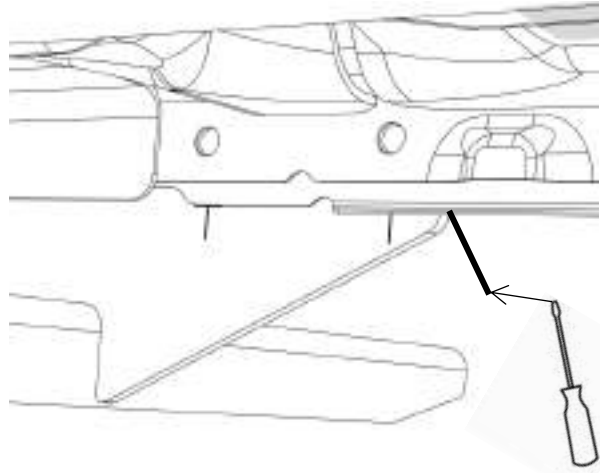

3

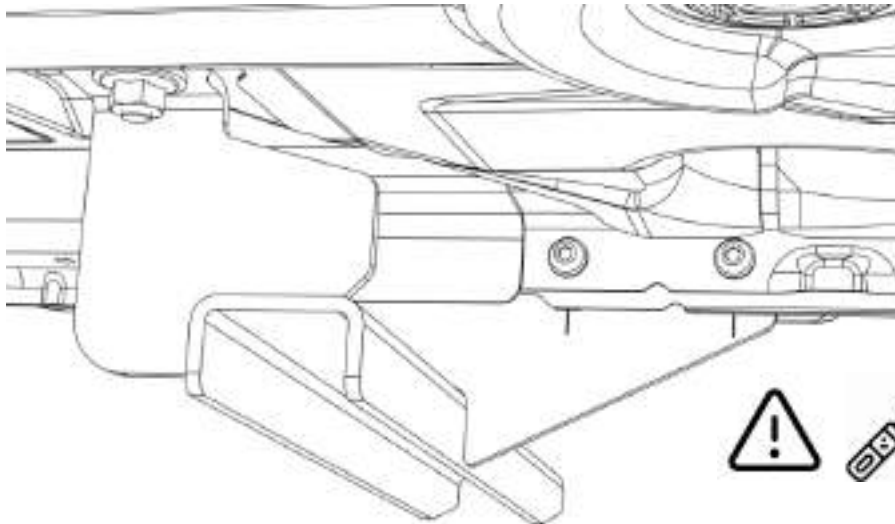

4mm, 11Nm

4

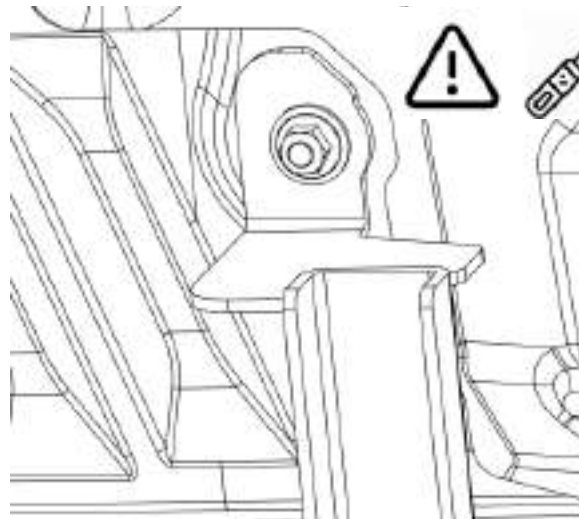

13mm, 24Nm



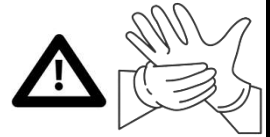

1

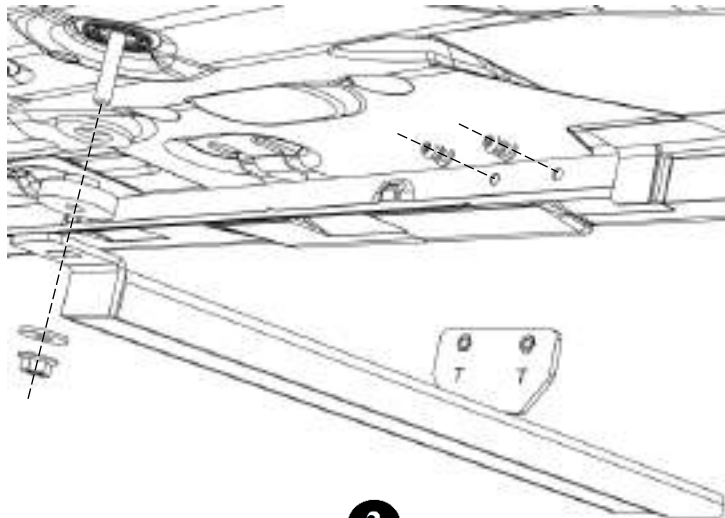

2

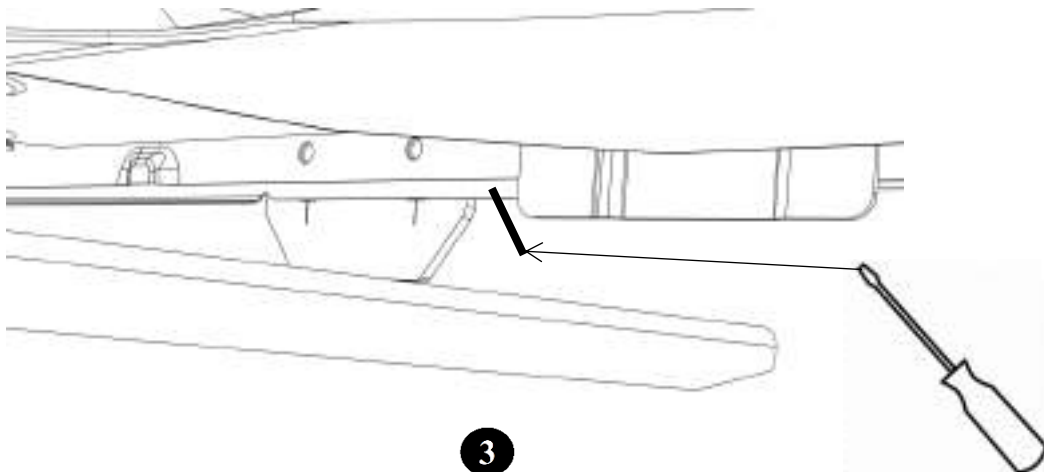

3

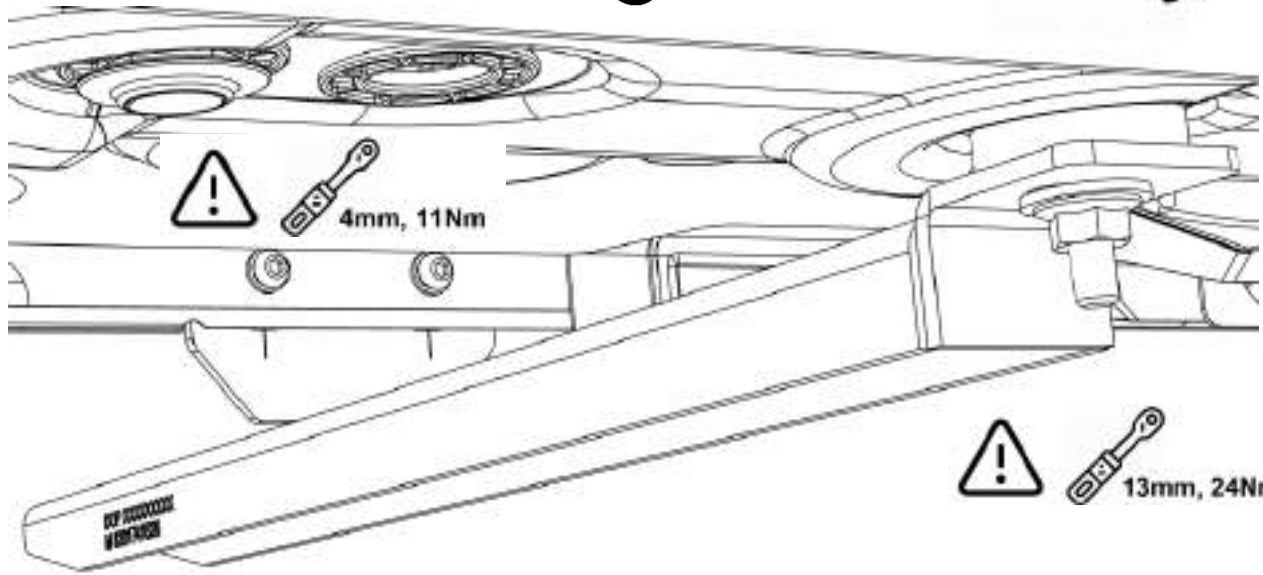



1

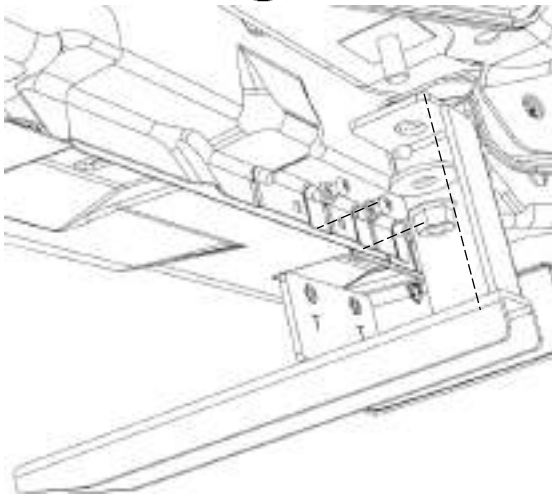

2

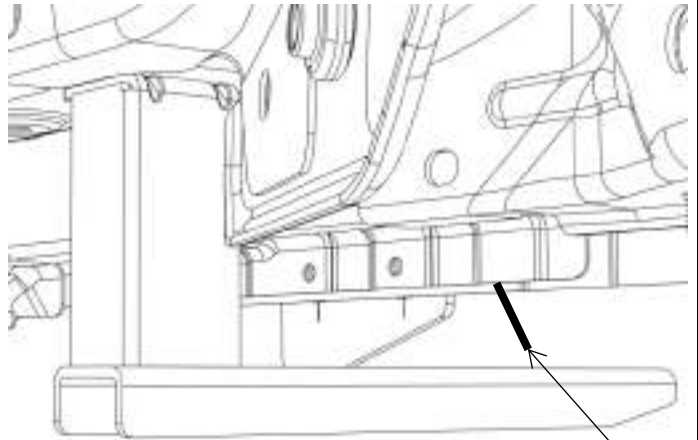

3

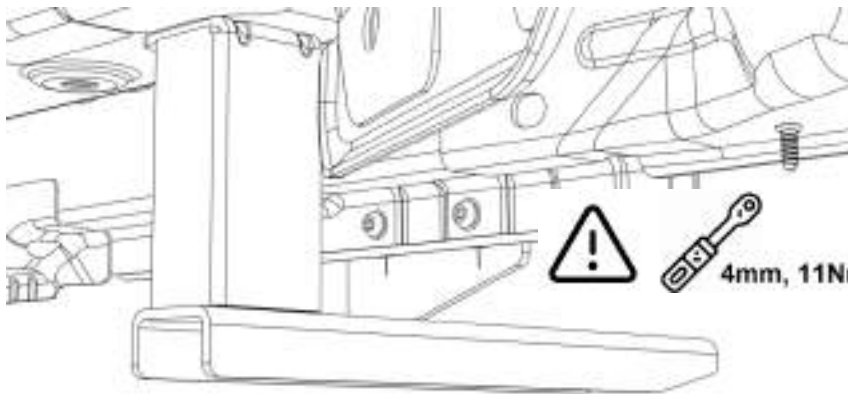

4mm, 11Nm

4

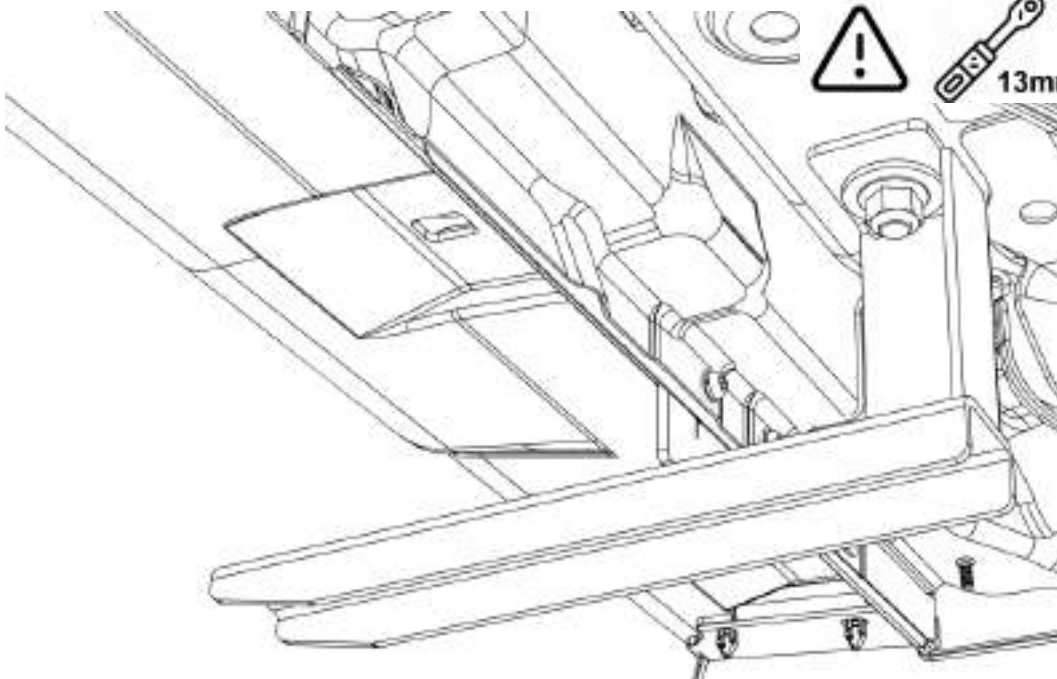

13mm, 24Nm

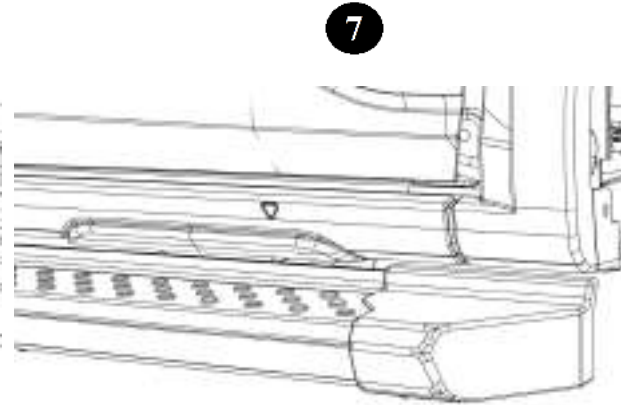
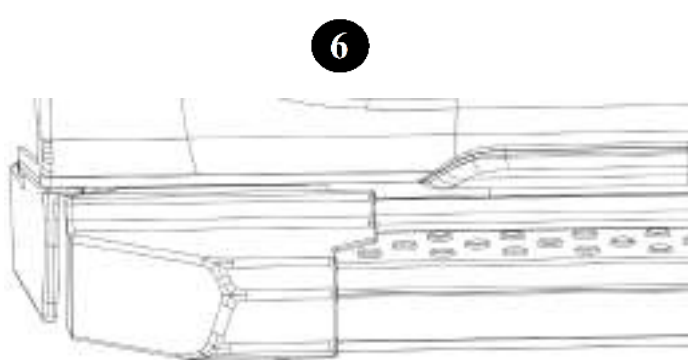
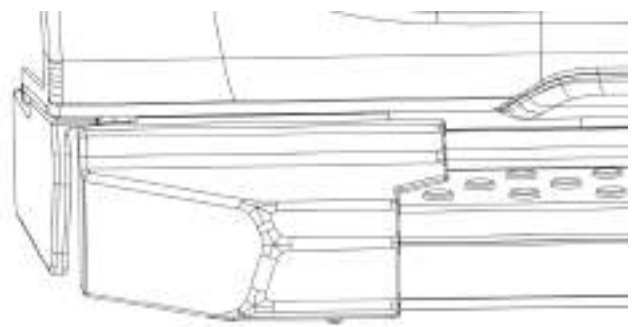
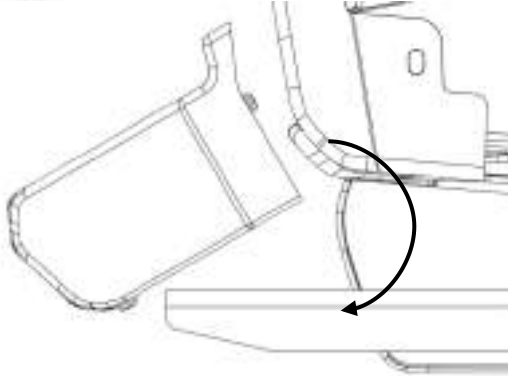
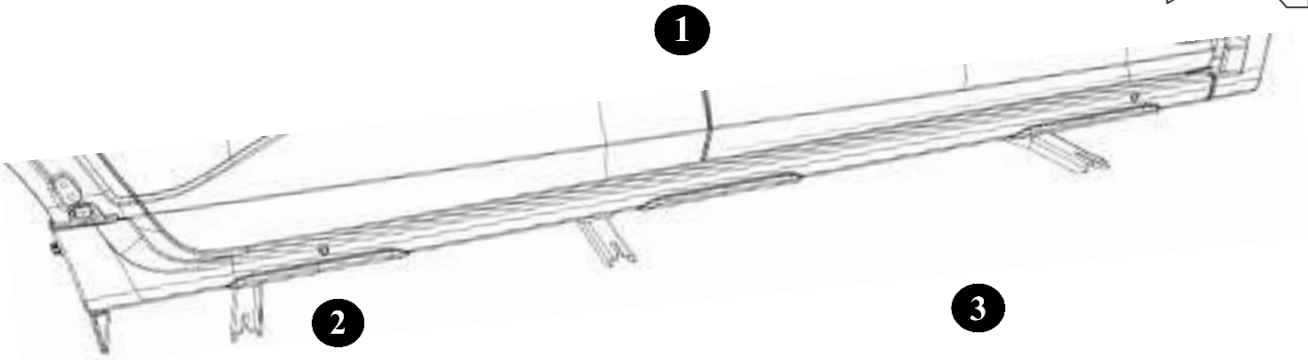

8

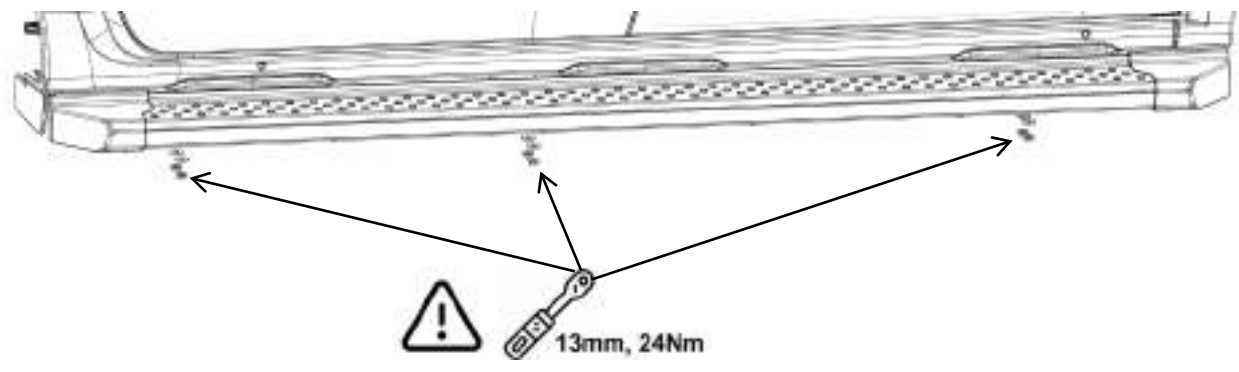

18

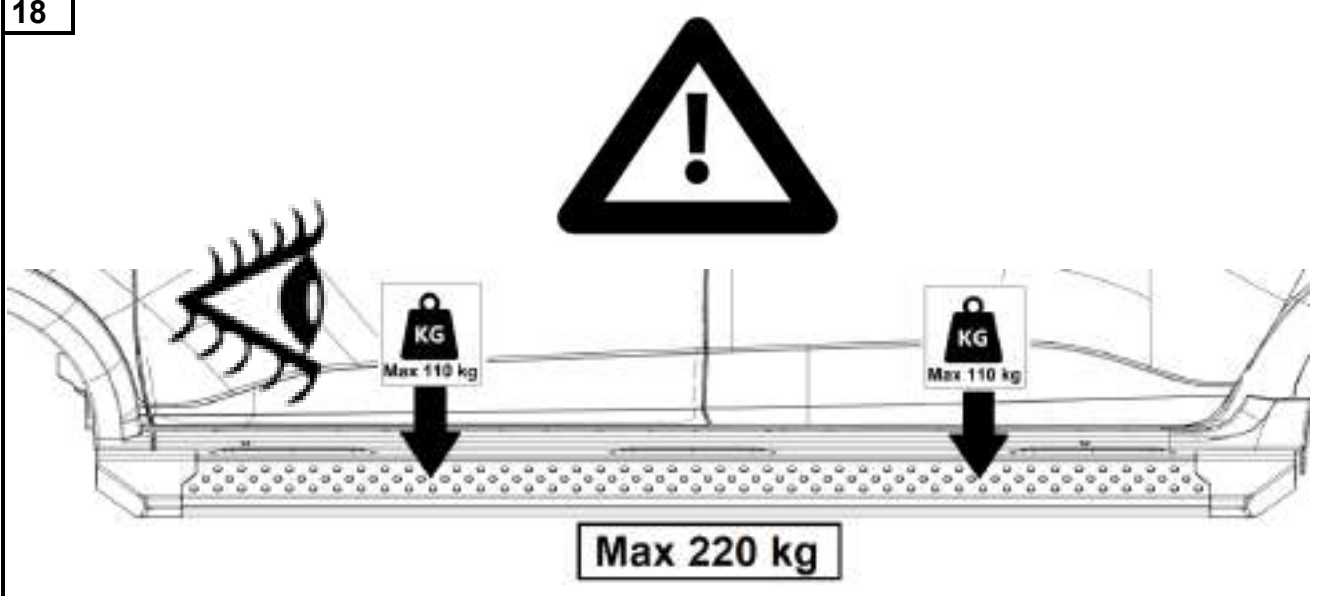

**FRA**

Les instructions de montage et/ou d'utilisation prescrites par le constructeur, dans ce présent document, sont établies en fonction des spécifications techniques en vigueur à la date d'établissement du document. Elles sont susceptibles de modifications en cas de changements apportés par le constructeur à la fabrication des différents organes et accessoires des véhicules de sa marque.

Ce produit ne doit pas être utilisé sur d'autres véhicules que ceux spécifiés par le constructeur. La sécurité est garantie si les instructions de montages et/ou d'utilisation sont respectées. Le non-respect de ces instructions et/ou la modification/réparation/entretien du produit en dehors de ces prescriptions, dégagent toute responsabilité du constructeur. Pour toutes questions, faites appel à un représentant de la marque

**CES**

Pokyny výrobce pro montáž a použití v tomto dokumentu jsou založeny na technických specifikacích, které byly aktuální k datu vytvoření tohoto dokumentu. Pokyny mohou být změněny v případě změn provedených výrobcem při výrobě různých částí a příslušenství vozidel jeho značky.

Tento produkt nesmí být používán na jiných než výrobcem uvedených vozidlech. Bezpečnost je zaručena při dodržení pokynů pro montáž a použití. Pokud pokyny nejsou dodrženy anebo je v rozporu s nimi na produktu provedena úprava/oprava/údržba, výrobce je zbaven jakékoliv odpovědnosti. V případě jakýchkoli dotazů se obraťte na zástupce značky.

**DNK**

Udstyret og/eller vejledningen er leveret af producenten og baseret på de tekniske specifikationer, der var gældende på det tidspunkt, hvor dokumentet blev udfærdiget. Opdateringer til vejledningen kan forekomme som en følge af ændringer, som producenten sidenhen indfører i produktionen af komponenter og tilbehør til køretøjerne.

Dette produkt bør ikke anvendes på andre køretøjer end de af producenten angivne. Såfremt udstyret og/eller vejledningen følges, er der garanti for sikkerhed. Hvis denne vejledning ikke følges og/eller ændring/reparation/vedligeholdelse af produktet ikke udføres i overensstemmelse med denne vejledning, er producenten fritaget for ethvert ansvar. Såfremt der skulle opstå spørgsmål, er du velkommen til at kontakte din Renault-repræsentant.

**DEU**

Die in diesem Dokument aufgeführten Montage- und/oder Bedienanleitungen des Herstellers basieren auf technischen Spezifikationen, die zum Zeitpunkt der Dokumenterstellung aktuell waren. Die Anleitungen können geändert werden, wenn der Hersteller verschiedene Komponenten oder Zubehörteile in seiner Fabrikation modifiziert."

Dieses Produkt sollte nicht in anderen Fahrzeugen als den Fahrzeugen eingesetzt werden, die durch den Hersteller spezifiziert wurden. Sicherheit ist nur gewährleistet, wenn die Montage- und/oder Bedienungsanleitungen befolgt werden. Falls diese Anleitungen nicht befolgt werden und/oder die Modifikations-/Reparatur-/Wartungsmaßnahmen des Produkts abweichend von diesen Anleitungen vorgenommen werden, stellt dies einen Haftungsausschluss des Herstellers dar. Falls Sie hierzu Fragen haben sollten, nehmen Sie Kontakt mit Ihrem Markenrepräsentanten auf.

**ENG**

The fitting and/or usage instructions given by the manufacturer in this document are based on the technical specifications current when the document was created. The instructions may be modified as a result of changes introduced by the manufacturer in the production of the various component units and accessories from which its vehicles are constructed. This product should not be used on vehicles other than those specified by the manufacturer. Safety is guaranteed if the fitting and/or usage instructions are adhered to. If these instructions are not adhered to and/or the modification/repair/maintenance of the product is carried out in non-compliance with these instructions, the manufacturer is released from any responsibility. If you have any questions, contact a representative of the brand.

**SPA**

Las instrucciones de montaje y/o uso facilitadas por el fabricante en este documento se basan en las especificaciones técnicas vigentes en el momento de creación del documento. Las instrucciones pueden ser modificadas en caso de cambios efectuados por el fabricante en la producción de los diversos órganos y accesorios a partir de los cuales se fabrican sus vehículos.

Este producto no debe usarse en vehículos distintos a los especificados por el fabricante. La seguridad está garantizada siempre que se respeten las instrucciones de montaje y/o uso. Si estas instrucciones no se respetan y/o la modificación/reparación/mantenimiento del producto se realiza sin seguir dichas instrucciones, el fabricante queda exento de toda responsabilidad. En caso de duda, ponerse en contacto con un representante de la marca.

**EST**

Selles dokumendis toodud tootja paigaldus- ja/või kasutusjuhised põhinevad dokumendi koostamise hetkel kehtivatel tehnilistel andmetel. Neid juhiseid võidakse muuta erinevate komponentide ja tarvikute tootjapoolse muutmise tulemusel, millest see sõiduk koosneb.

Seda toodet ei tohi kasutada muudel, tootja poolt märkimata sõidukitel. Ohutus tagatakse paigaldamis- ja/või kasutusjuhistest kinnipidamisel. Kui nendest juhistest kinni ei peeta ja toodet muudetakse/remonditakse/hooldatakse juhistest kinni pidamata, vabastatakse tootja igasugusest vastutusest. Küsimuste tekkimisel võtke ühendust toote esindajaga.

**FIN**

Valmistajan tässä asiakirjassa antamat asennus- ja/tai käyttöohjeet perustuvat asiakirjan luontihetkellä voimassa oleviin teknisiin tietoihin. Ohjeet saattavat muuttua, mikäli valmistaja muuttaa ajoneuvojensa eri komponenttiyksiköiden ja lisävarusteiden valmistusta.

Tätä tuotetta ei tule käyttää muissa kuin valmistajan määrittelemissä ajoneuvoissa. Turvallisuus on taattu, jos asennus- ja/tai käyttöohjeita noudatetaan. Valmistaja ei ole vastuussa, mikäli näitä ohjeita ei noudateta ja/tai tuotetta muokataan, korjataan tai huolletaan näiden ohjeiden vastaisesti. Jos sinulla on kysyttävää, ota yhteyttä merkin edustajaan.

**ELL**

Οι οδηγίες τοποθέτησης ή/και χρήσης που παρέχονται από τον κατασκευαστή στο παρόν έγγραφο βασίζονται στις τεχνικές εγκυκλίους που ίσχυαν κατά τη δημιουργία του. Ενδέχεται να υπάρξουν τροποποιήσεις στις οδηγίες σε περίπτωση που ο κατασκευαστής επιφέρει αλλαγές στην κατασκευή των διαφόρων οργάνων και εξαρτημάτων των αυτοκινήτων της μάρκας του.

Το παρόν προϊόν δεν ενδείκνυται για χρήση σε αυτοκίνητα πέραν εκείνων που ορίζονται από τον κατασκευαστή. Η ασφάλεια είναι εφόσον τηρούνται οι οδηγίες τοποθέτησης ή/και χρήσης. Σε

αντίθετη περίπτωση ή/και εφόσον η τροποποίηση/επισκευή/συντήρηση του προϊόντος διενεργείται χωρίς να τηρούνται οι παρούσες οδηγίες, ο κατασκευαστής απαλλάσσεται από οποιαδήποτε ευθύνη. Για οποιαδήποτε ερώτηση, επικοινωνήστε με τον αντιπρόσωπο.

**HRV**

Upute proizvođača za montažu i/ili upotrebu navedene u ovom dokumentu temelje se na tehničkim specifikacijama važećima u vrijeme izrade dokumenta. Upute su podložne izmjenama u slučaju promjena kod proizvođača u proizvodnji različitih sastavnih dijelova i dodatne opreme vozila.

Ovaj proizvod ne smije se upotrebljavati za vozila koja nije odredio proizvođač. Sigurnost je zajamčena jedino u slučaju pridržavanja uputa za montažu i/ili upotrebu. U slučaju nepridržavanja ovih uputa i/ili postupaka promjene/popravka/održavanja proizvoda koji nisu sukladni ovi uputama, proizvođač ne snosi nikakvu odgovornost. U slučaju pitanja, obratite se predstavniku marke.

**HUN**

A gyártó dokumentumban olvasható beszerelési és/vagy használati utasításai a dokumentum szerkesztésekor érvényes műszaki adatokat veszik figyelembe. A gépkocsi-alkatrészek gyártási eljárásának megváltozása miatt előfordulhat, hogy az utasítások is módosulnak.

A termék kizárólag a gyártó által meghatározott gépkocsikban alkalmazható. A biztonságos működés a termék utasításoknak megfelelő beszerelése és használata esetén szavatolt. Az utasítások be nem tartása és/vagy a terméknek az utasításoknak nem megfelelő módon való módosítása, javítása, illetve karbantartása esetén a gyártó mindennemű felelősségtől mentesül. Kérdéseivel kapcsolatban a márka képviselőjénél érdeklődhet.

**ITA**

Le istruzioni sul montaggio e/o l'utilizzo fornite dal produttore nel presente documento sono basate sulle caratteristiche tecniche presenti al momento della creazione del documento. Tali istruzioni sono soggette a modifiche qualora il costruttore apporti delle modifiche nella produzione dei diversi accessori e unità dei componenti dei veicoli.

Questo prodotto non deve essere utilizzato su veicoli diversi da quelli specificati dal costruttore. Se si rispettano le istruzioni sul montaggio e/o l'utilizzo, la sicurezza è garantita. In caso di mancata osservanza delle presenti istruzioni e/o di esecuzione di modifiche/riparazioni/manutenzione del prodotto non conformi alle istruzioni, il costruttore è sollevato da ogni responsabilità. In caso di domande, contattare un rappresentante del marchio.

**JPN**

本本に記記ささささ取取け手手使使手手は、本本本本の技技技技に基づさささづづ。 /

車車ののののののの、取付付の変変に伴さ、内内が変わさわわがわわさづづのわ、予めわ了了くくささ。

わの製付は、メのメ指指の車車車車に使使ししわくくささ。取取け手手 / 使使手手に従っささくく場場に安安安が保保ささづづ。

わさこの手手に従わしさ場場、おおおづつはわさこの手手に従わわに製付の改改修修 / / /

メのメメのメメ実実しつ場場、メのメは責責メ負さづいい。わ不不し点がわわさづしっこ、ブのブ担担担にお問さ場わいくくささ。

**KOR**

제제제제제제제제제제장장및또제사용지지지해해문서작작해해당당최최기기사사사기기기합합합 / . 차차 제작제

사용사제 합사다 구작구구 유유 및 구부구당 생생 과과제서 제제제제제 당다 변변 사사사 있사 변경 관관 지지사 수과수 수 있있합합.

사 제구지 제제제제제당해지과지 차차 사이당 차차제서제 사용수 수 없있합합. 안안사 보장 받기받받 장장 및/또제

사용 지지사 준수해준 합합합. 지지사 준수제지 않않않 지지제 따따지 않않 제구당 변변/수수/유지 보수보 수수다

변경 제제제제제 일제당 책책사 지지 않있합합. 문당 사사사 있제 변경 해해 브브브당 대수대제대 문당제문당문.

**LIT**

Šiame dokumente gamintojo pateiktos montavimo ir/arba laikymo instrukcijos yra paremtos techninėmis specifikacijomis, galiojančiomis dokumento sudarymo metu. Instrukcijos gali būti keičiamos dėl gamintojo pateiktų įvairių komponentų ir priedų, naudojamų transporto priemonių gamyboje, pakeitimų gamybos metu. Šis produktas negali būti naudojamas kitoms transporto priemonėms nei nurodyta gamintojo. Saugumas užtikrinamas laikantis nurodytų montavimo ir/arba naudojimo instrukcijų. Nesilaikant šių instrukcijų ir/arba jei produkto keitimas/remontas/priežiūra atliekama nesilaikant šių instrukcijų, gamintojas atleidžiamas nuo bet kokios atsakomybės. Jei turite klausimų, prašome susisiekti su prekių platintoju.

**LAV**

Šajā dokumentā sniegto ražotāja norādījumu piemērošana un lietošana ir balstīta uz tehniskajām specifikācijām, kas bija spēkā brīdī, kad dokuments tika izveidots. Norādījumi var tikt mainīti, ja ražotājs ievieš izmaiņas transportlīdzekļu konstrukcijā izmantoto detaļu elementu un piederumu ražošanā. Šis izstrādājums nav pielietojams transportlīdzekļiem, ko nav norādījis ražotājs. Drošība tiek garantēta, ja tiek izpildīti piemērošanas un/vai lietošanas norādījumi. Ražotājs tiek atbrīvots no jebkādas atbildības, ja šie norādījumi nav izpildīti un ir veikta izstrādājuma pārveidošana/remonts/apkope neatbilstoši šiem norādījumiem. Jautājumu gadījumā sazināties ar zīmola pārstāvi.

**NLD**

De door de constructeur verstrekte montage- en/of gebruiksvoorschriften, zoals in dit document beschreven, zijn gemaakt volgens de technische richtlijnen geldend op het tijdstip dat dit document werd samengesteld. Deze voorschriften zijn aan verandering onderhevig indien de constructeur tussentijds constructiewijzigingen op onderdelen of accessoires heeft aangebracht. Dit product mag niet worden gebruikt op andere voertuigen dan dedoor de constructeur genoemde. De veiligheid wordt gegarandeerd wanneer de montage- en/of gebruiksvoorschriften zijn nageleefd. Als deze voorschriften niet zijn nageleefd en/of wijziging/reparatie/onderhoud van het product niet is uitgevoerd volgens deze voorschriften, dan is de constructeur van zijn aansprakelijkheid ontheven. Neem bij vragen contact op met de vertegenwoordiger van het merk.

**NOR**

Monterings- og/eller bruksanvisningene fra produsenten i dette dokumentet er basert på de tekniske spesifikasjonene som gjaldt da dokumentet ble opprettet. Anvisningene kan endres som et resultat av endringer foretatt av produsenten i produksjonen av de forskjellige komponenthetene og tilbehørene som utgjør kjøretøyet.

Dette produktet skal ikke brukes på andre kjøretøy enn de som er spesifisert av produsenten. Sikkerheten garanteres hvis monterings- og/eller bruksanvisningene følges. Hvis disse anvisningene ikke følges og/eller endringen/reparasjonen/vedlikeholdet av produktet utføres i uoverensstemmelse med disse instruksjonene, frites produsenten fra alt ansvar. Ta kontakt med en representant for merket hvis du har spørsmål.

**POL**

Instrukcje montażu/obsługi zawarte przez producenta w tym dokumencie zostały oparte na danych technicznych aktualnych w momencie powstania dokumentacji. Mogą one ulec zmianie w przypadku wprowadzenia przez producenta modyfikacji procesu produkcji różnych podzespołów i akcesoriów pojazdów tej marki.

Tego zespołu nie można wykorzystywać w pojazdach innych niż określone przez producenta. Tylko przestrzeganie instrukcji montażu i obsługi gwarantuje odpowiednie bezpieczeństwo. W przypadku nieprzestrzegania instrukcji i/lub wykonania modyfikacji/napraw/konserwacji produktu w sposób niezgodny z niniejszymi instrukcjami, producent nie ponosi żadnej odpowiedzialności. W przypadku pytań należy skontaktować się z przedstawicielem marki.

**POR**

As instruções de montagem e/ou de utilização fornecidas pelo construtor incluídas neste documento são baseadas nas características técnicas no momento em que o documento foi criado. As instruções poderão ser modificadas em função de alterações introduzidas pelo construtor no fabrico dos diferentes órgãos e acessórios dos veículos.

Este produto não deve ser utilizado em veículos diferentes dos especificados pelo construtor. A segurança é garantida se as instruções de montagem e/ou de utilização forem respeitadas. Se estas instruções não forem respeitadas e/ou a modificação/reparação/manutenção do produto não for realizada em conformidade com estas instruções, o construtor não assumirá qualquer responsabilidade. Em caso de dúvidas, contactar um representante da marca.

**RON**

Instrucțiunile de montare și/sau de utilizare furnizate de constructor în prezentul document se bazează pe specificațiile tehnice în vigoare la momentul creării documentului. Instrucțiunile sunt susceptibile de a fi modificate în cazul schimbărilor aduse de constructor în fabricarea diferitelor organe și accesorii ale vehiculelor mărcii sale.

Acest produs nu trebuie utilizat pe alte vehicule decât cele specificate de constructor. Siguranța este garantată dacă se respectă instrucțiunile de montare și/sau utilizare. Dacă nu se respectă aceste instrucțiuni și/sau modificarea/reparația/întreținerea produsului este realizată în neconformitate cu aceste instrucțiuni, constructorul este absolvit de orice responsabilitate. Dacă aveți orice întrebări, contactați un reprezentant al mărcii.

## RUS

Инструкции производителя по установке и применению в данном документа основаны на технических характеристиках, актуальных на момент создания документа. В случае внесения изменений в процесс изготовления деталей, узлов, агрегатов производимых им автомобилями инструкции также могут быть соответственно изменены.

Запрещается использовать этот продукт на моделях автомобилей, не указанных производителем. Производитель гарантирует безопасность продукта только при строгом соблюдении инструкций по установке и применению. В случае несоблюдения данных инструкций и/или в случае проведения работ по усовершенствованию / ремонту / обслуживанию продукта без соблюдения данных инструкций производитель освобождается от любой ответственности. Если у Вас возникли вопросы, свяжитесь с представителем компании- производителя.

## SLV

Navodila namestitev in/ali zamenjavo, ki jih navaja proizvajalec v tem dokumentu, so izdelana na podlagi tehničnih specifikacij, veljavnimi na dan izdelave tega dokumenta. Ta navodila se lahko spremenijo v primeru uvedbe sprememb pri izdelavi različnih delov in dodatne opreme, ki so sestavni del i vozil.

Tega izdelka ni dovoljeno uporabiti pri vozilih, ki jih proizvajalec ne navede izrecno. Varnost je zagotovljena, če so upoštevana vsa navodila za namestitev in/ali uporabo. Če teh navodil ne upoštevate in/ali spremembe/popravila/vzdrževanje izdelka opravite v nasprotju s temi navodili, proizvajalec ne prevzema nikakršne odgovornosti. Če imate kakršna koli vprašanja, se obrnite na predstavnika znamke.

## SLK

Pokyny na inštaláciu a použitie uvádzané výrobcom v tomto dokumente sú založené na technických špecifikáciách platných v čase vzniku dokumentu. Pokyny môžu byť upravené v dôsledku zmien zavedených výrobcom vo výrobnom procese jednotlivých súčiastok a príslušenstva, z ktorého pozostávajú jeho vozidlá.

Tento výrobok sa môže používať len vo vozidlách stanovených výrobcom. Bezpečnosť je zaistená v prípade, že sú dodržané pokyny na inštaláciu a použitie. Výrobca nenesie zodpovednosť v prípade, že sa nedodržia tieto pokyny alebo sa vykoná úprava/oprava/údržba výrobku, ktorá nie je v súlade s týmito pokynmi.

V prípade akýchkoľvek otázok sa obráťte na zástupcu značky.

## SWE

De instruktioner för montering och/eller användning som ges av tillverkaren i detta dokument är baserade på de tekniska specifikationerna som var aktuella när dokumentet skapades. Instruktionerna kan ändras som ett resultat av tillverkarens konstruktionsändringar av de olika delar och tillbehör som fordonet är uppbyggt av.

Den här produkten bör inte användas på andra fordon än de som anges av tillverkaren. Säkerheten garanteras om instruktionerna för montering och/eller användning följs. Tillverkaren är befriad från alla ansvarsanspråk om dessa instruktioner inte följs och/eller modifiering/reparation/underhåll av produkten sker utan att dessa instruktioner följs. Om du har några frågor, kontakta en representant för varumärket.

## TUR

Üreticinin bu dokümanda belirtmiş olduđu montaj ve/veya kullanım talimatları, doküman oluşturulduğunda geçerli olan teknik özelliklere dayalıdır. Bu talimatlar, üretici tarafından araçların çeşitli aksam gruplarının ve aksesuarlarının imalatında yapılabilecek modifikasyonlar doğrultusunda değiştirilebilir.

Bu ürün, üretici tarafından belirtilen araçlar dışında başka araçlar üzerinde kullanılmamalıdır. Montaj ve/veya kullanım talimatlarına uyulduđu takdirde güvenlik garantisi verilir. Bu talimatlara uyulmadığı ve/veya ürünün modifikasyon/onarım/bakımı bu talimatlara uygun olarak gerçekleştirilmediği takdirde, üretici hiçbir sorumluluk kabul etmez. Herhangi bir sorunuz olursa bir marka temsilcisiyle iletişime geçin.